

CIAO FIAT
00 800 342 800 00
Customer Assistance Service

A single number to feel special. Call 00.800.3428.0000 free from all over Europe* to request: ROADSIDE ASSISTANCE, towing and intervention in the event of breakdown and accidents (24 hours a day, 7 days a week). INFORMATION, details and assistance on models, services, sales network and test drives.

*Check whether your call will be free by contacting your network operator..

CIAO FIAT
PROFESSIONAL MOBILI
Available on the
App Store Google play



Ciao Fiat Professional Mobile is the original Fiat Professional application for all its customers. You can access a range of services and assistance at the touch of a finger, wherever you are.

VEHICLE WARRANTY

2-year Unlimited Mileage Manufacturer Warranty

Any repairs required as the result of faulty materials or manufacturer are carried out free of charge – either for parts or labour.

3rd Year Dealer Warranty*

Any repairs required as the result of faulty materials or manufacture - either for parts or labour are covered up to 120,000 miles (60,000 miles on passenger versions registered for hire & reward usage) from the date of first registration or the expiry of the 3rd year, whichever occurs first. The warranty is provided free of charge and is subject to conditions (full details are available from your Fiat dealer).

* Only applicable to UK-sourced vehicles from Fiat Chrysler Automobiles UK Ltd. Excludes Motorhome / Camper Conversions and Export Vehicles.

Paintwork warranty

The vehicle is guaranteed against manufacturing defects in the paintwork for a period of 36 months from the handover date. The warranty provides for the total or partial repainting of the vehicle to eliminate any proven failure, according to the Manufacturer's standard conditions.

Perforating corrosion warranty

The structural elements of the vehicle bodywork are guaranteed against perforation caused by corrosion, when it occurs from the inside out. The Warranty provides for the repair and/or replacement of any original, bodywork structural element damaged by perforating corrosion and is valid for 8 years from when the vehicle is handed over. We advise you to check the specific conditions of your cover in your warranty booklet.

Model trim levels and optional extras may vary according to specific market or legal requirements. The details contained in this publication are purely indicative. Fiat may change the models described in this publication at any time for reasons of a technical or commercial nature.
Fiat Marketing 02.3.2389.52 - S - 02/2015 - Printed in Italy - Tap Grafiche - Poggibonsi - Siena.
Publication printed on chlorine-free paper.

www.fiatprofessional.co.uk

NEW DOBLÒ CARGO.



TECHNICAL SPECIFICATIONS AND MAIN EQUIPMENT



Technical specifications

	95 MPI	90 MULTIJET II	90 MULTIJET II COMFORT MATIC	105 MULTIJET II	135 MULTIJET II					
Engine										
No. of cylinders, layout	4 in line, transverse front	4 in line, transverse front	4 in line, transverse front	4 in line, transverse front	4 in line, transverse front					
Displacement (cm ³)	1368	1248	1598	1598	1956					
Emissions level	Euro 6 / Euro 6 with Start&Stop	Euro 5+ with DPF / Euro 5+ with DPF and Start&Stop / Euro 5+ with DPF, S&S & ECOPack	Euro 5+ with DPF and Start&Stop	Euro 5+ with DPF / Euro 5+ with DPF and Start&Stop / Euro 5+ with DPF, S&S & ECOPack	Euro 5+ with DPF					
Compression ratio	11:01	16.8:1	16.5:1	16.5:1	16.5:1					
EC max. power: HP at RPM	95 at 6000	90 at 4000	90 at 4000	105 at 4000	135 at 3500					
EC max. torque: Nm at rpm	127 at 4500	200 at 1500	200 at 1500	290 at 1500	320 at 1500					
Timing system (control)	2 OHC (toothed belt) with hydraulic tappets 4 valves per cylinder	2 OHC (with chain) with hydraulic tappets 4 valves per cylinder	2 OHC (toothed belt) with hydraulic tappets 4 valves per cylinder							
Fuel	petrol (EN228)	diesel fuel for motor vehicles (EN 590)	diesel fuel for motor vehicles (EN 590)	diesel fuel for motor vehicles (EN 590)	diesel fuel for motor vehicles (EN 590)					
Supply	timed sequential, returnless system	MultiJet II "Common Rail" direct injection with electronic control, turbo and intercooler	MultiJet II "Common Rail" direct injection with electronic control, turbo and intercooler	MultiJet II Common Rail direct injection with electronic control, turbo and intercooler	MultiJet II Common Rail direct injection with electronic control, turbo and intercooler					
Ignition	electronic, static, integrated with the injection	by compression	by compression	by compression	by compression					
Transmission										
Drive	front	front	front	front	front					
Clutch	dry, single plate with cup engagement spring and hydraulic operation	dry, single plate with cup engagement spring and hydraulic operation	dry, single plate with electro-hydraulic activation	dry, single plate with cup engagement spring and hydraulic operation	dry, single plate with cup engagement spring and hydraulic operation					
Gearbox: number of gears	5 + R	5 + R	5 + R with electronically managed electro-hydraulic control system	6 + R	6 + R					
Steering										
Type	rack and pinion with hydraulic power steering	rack and pinion with hydraulic power steering	rack and pinion with hydraulic power steering	rack and pinion with hydraulic power steering	rack and pinion with hydraulic power steering					
Turning circle (kerb to kerb)	11.2/12.5 (Maxi)	11.2/12.5 (Maxi)	11.7 / 13 (Maxi and XL)	11.2/12.5 (Maxi and XL)	11.2/12.5 (Maxi and XL)					
Braking system - D (self-ventilated disc) - T (drum)										
Type	hydraulic system with 2 crossover independent circuits		hydraulic system with 2 crossover independent circuits							
Front: ø (mm)	D 305	D 284 - D 305 (Maxi and increased payload)	D 284 - D 305 (Maxi and increased payload)	D 284 - D 305 (Maxi and increased payload)	D 305					
Rear: ø mm	T 254	T 228 - T 254 (Maxi, increased payload and Combi)	T 228 - T 254 (Maxi, increased payload and Combi)	T 228 - T 254 (Maxi, increased payload and Combi)	T 254					
Brake servo: ø	10"	10"	10"	10"	10"					
Suspension										
Front	independent, MacPherson type with wishbones secured to an auxiliary crossmember, telescopic hydraulic shock absorbers, coil springs and anti-roll bar	independent, MacPherson type with wishbones secured to an auxiliary crossmember, telescopic hydraulic shock absorbers, coil springs and anti-roll bar								
Rear	Bi-link independent, coil springs, telescopic shock absorbers with dual calibration and anti-roll bar (according to version)	Bi-link independent, coil springs, telescopic shock absorbers with dual calibration and anti-roll bar (according to version)	Bi-link independent, coil springs, telescopic shock absorbers with dual calibration and anti-roll bar (according to version)	Bi-link independent, coil springs, telescopic shock absorbers with dual calibration and anti-roll bar (according to version)	Bi-link independent, coil springs, telescopic shock absorbers with dual calibration and anti-roll bar (according to version)					
Wheels										
Tyres	195/60 R 16	185/65 R 15 - 195/65 R 15 (Combi) 195/60 R 16 (Maxi and increased capacity)	185/65 R 15 - 195/65 R 15 (Combi) 195/60 R 16 (Maxi and increased capacity)	185/65 R 15 - 195/65 R 15 (Combi) 195/60 R 16 (Maxi and increased capacity)	195/60 R 16					
Electrical system (12 V)										
Battery capacity (Ah)	40/50/60/63/72	50/60/63/70/72	72	60/70/72	60/70/72					
Alternator current (A)	70/90/105/120	70/90/120	100/120/150	100/120/150	100/120/150					
Refuelling										
Fuel tank capacity (litres)	60	60	60	60	60					
Performance and consumption - Cargo short wheelbase										
	E6	E6 with S&S	E5+ with DPF	E5+ with DPF and S&S	E5+ ECOJET 90 HP with DPF, S&S and ECOPack	E5+ with DPF and S&S	E5+ with DPF	E5+ with DPF and S&S	E5+ ECOJET with DPF, S&S and ECOPack	E5+ with DPF
Top speed (mph)	100	100	98	98	98	98	102	102	102	111
Combined consumption (mpg)	38.7	40.4	56.5	58.9	64.2	57.6	52.3	54.3	60.1	47.9
CO ₂ emissions (g/km)	169	163	133	126	115	130	143	136	124	154

■ values referring to Cargo short wheelbase with increased payload

DOBLÒ CARGO

Standard short wheelbase

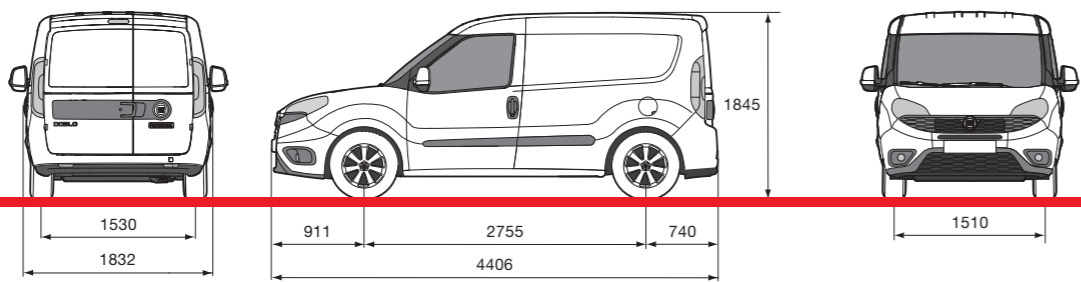

External dimensions (mm)	
Wheelbase	2755
Length	4406
Width	1832
Front track	1510
Rear track	1530
Maximum height (unladen)	1845
Front projection	911
Rear projection	740
Rear door (mm)	
Width	1231
Height	1250
Sliding side door (mm)	
Width	700
Height	1175
Load compartment (mm)	
Length	1820
Width	1714
Width between wheel arches	1230
Height	1305
Load threshold height (unladen)	545
Load compartment capacity (m³)	
Volume	3.4

Weights	Standard van					Increased payload van				
	95 MPI	90 MultiJet II	90 MultiJet II Comfort-Matic	105 MultiJet II	135 MultiJet II	95 MPI	90 MultiJet II	90 MultiJet II Comfort-Matic	105 MultiJet II	135 MultiJet II
Vehicle weight* (tare) (kg)	1280	1320	1350	1350	1403	1310	1350	1420	1420	1430
Payload including driver (kg)	750	750	750	750	750	900	1005	1005	1005	1005
GVW (kg)	2030	2070	2100	2100	2153	2210	2355	2425	2425	2435
Max. towable weight (kg)	1000	1000	1300	1300	1500	1000	1000	1300	1300	1500

Fuel consumption - Emissions	Standard van									
	95 MPI		90 MultiJet II			90 MultiJet II Comfort-Matic		105 MultiJet II		
Engine versions	E6	E6 S&S	E5+ DPF	E5+ DPF S&S	E5+ 90 HP ECOJet DPF S&S Ecopack	E5+ DPF S&S	E5+ DPF	E5+ DPF S&S	E5+ ECOJet DPF S&S Ecopack	E5+ DPF
Fuel	petrol	petrol	diesel	diesel	diesel	diesel	diesel	diesel	diesel	diesel
Urban consumption (mpg)	28.5	30.7	43.5	47.9	54.3	51.4	42.2	46.3	52.3	39.2
Extra-urban consumption (mpg)	48.7	49.6	67.3	67.3	72.4	61.4	60.1	61.4	65.7	55.4
Combined consumption (mpg)	38.7	40.4	56.5	58.9	64.2	57.6	52.3	54.3	60.1	47.9
CO ₂ emissions (g/km)	169	163	133	126	115	130	143	136	124	154

Fuel consumption - Emissions	Increased payload van									
	95 MPI		90 MultiJet II			90 MultiJet II Comfort-Matic		105 MultiJet II		
Engine versions	E6	E6 S&S	E5+ DPF	E5+ DPF S&S	E5+ 90 HP ECOJet DPF S&S Ecopack	E5+ DPF S&S	E5+ DPF	E5+ DPF S&S	E5+ ECOJet DPF S&S Ecopack	E5+ DPF
Fuel	petrol	petrol	diesel	diesel	diesel	diesel	diesel	diesel	diesel	diesel
Urban consumption (mpg)	27.2	29.1	43.5	47.9	54.3	50.4	41.5	45.6	51.4	39.2
Extra-urban consumption (mpg)	48.7	47.9	67.3	67.3	72.4	60.1	60.1	61.4	65.7	55.4
Combined consumption (mpg)	37.7	38.7	56.5	58.9	64.2	56.5	51.4	54.3	62.8	47.9
CO ₂ emissions (g/km)	174	168	133	126	115	133	144	137	125	154

* Referred to basic versions without optional equipment

DOBLÒ CARGO

Maxi

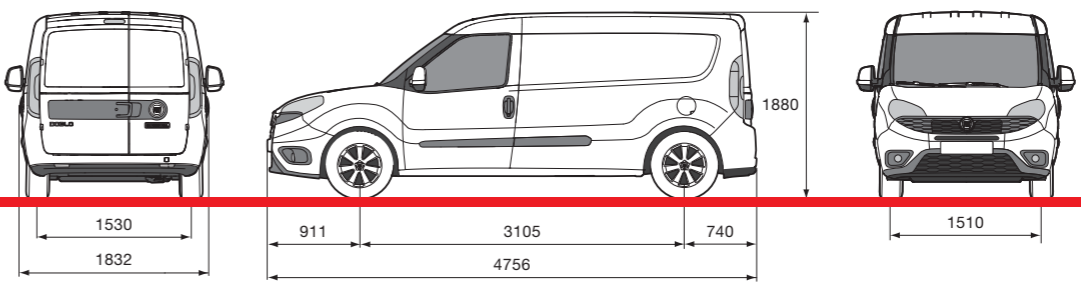

External dimensions (mm)	
Wheelbase	3105
Length	4756
Width	1832
Front track	1510
Rear track	1530
Maximum height (unladen)	1880
Front projection	911
Rear projection	740
Rear door (mm)	
Width	1231
Height	1250
Sliding side door (mm)	
Width	700
Height	1175
Load compartment (mm)	
Length	2170
Width	1714
Width between wheel arches	1230
Height	1305
Load threshold height (unladen)	545
Load compartment capacity (m³)	
Volume	4.2

Weights	Van					Van payload 750 kg	
	95 MPI	90 MultiJet II	90 MultiJet II Comfort-Matic	105 MultiJet II	135 MultiJet II	90 MultiJet II	105 MultiJet II
Vehicle weight* (tare) (kg)	1315	1415	1460	1460	1460	1406	1420
Payload including driver (kg)	900	1005	1005	1005	1005	750	750
GVW (kg)	2215	2420	2465	2465	2465	2156	2170
Max. towable weight (kg)	1000	1000	1300	1300	1500	1000	1300

Fuel consumption - Emissions	Van									
	95 MPI		90 MultiJet II			90 MultiJet II Comfort-Matic		105 MultiJet II		
Engine versions	E6	E6 S&S	E5+ DPF	E5+ DPF S&S	E5+ 90 HP ECOJet DPF S&S Ecopack	E5+ DPF S&S	E5+ DPF	E5+ DPF S&S	E5+ ECOJet DPF S&S Ecopack	E5+ DPF
Fuel	petrol	petrol	diesel	diesel	diesel	diesel	diesel	diesel	diesel	diesel
Urban consumption (mpg)	27.2	29.1	43.5	47.1	53.3	50.4	41.5	45.6	51.4	39.2
Extra-urban consumption (mpg)	48.7	47.9	67.3	65.7	70.6	60.1	60.1	61.4	65.7	55.4
Combined consumption (mpg)	37.7	38.7	56.5	57.6	62.8	56.5	51.4	54.3	60.1	47.9
CO ₂ emissions (g/km)	174	168	133	129	118	133	144	137	125	154

* Referred to basic versions without optional equipment

DOBLÒ CARGO

High roof short wheelbase

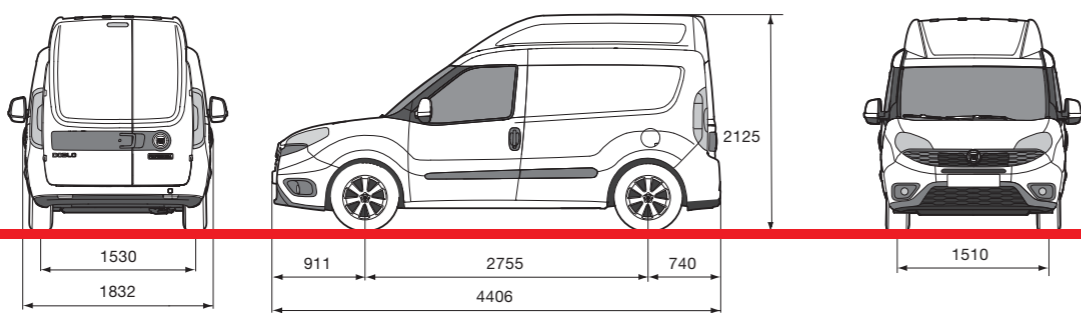

External dimensions (mm)	
Wheelbase	2755
Length	4406
Width	1832
Front track	1510
Rear track	1530
Maximum height (unladen)	2125
Front projection	911
Rear projection	740
Rear door (mm)	
Width	1231
Height	1455
Sliding side door (mm)	
Width	700
Height	1175
Load compartment (mm)	
Length	1820
Width	1714
Width between wheel arches	1230
Height	1550
Load threshold height (unladen)	545
Load compartment capacity (m ³)	
Volume	4.0

Weights	Standard van				Increased payload van			
	95 MPI	90 MultiJet II Comfort-Matic	105 MultiJet II	135 MultiJet II	95 MPI	90 MultiJet II Comfort-Matic	105 MultiJet II	135 MultiJet II
Engine versions								
Vehicle weight * (tare) (kg)	1290	1393	1393	1420	1315	1430	1430	1460
Payload including driver (kg)	750	750	750	750	900	1005	1005	1005
GVW (kg)	2040	2143	2143	2170	2215	2435	2435	2465
Max. towable weight (kg)	1000	1300	1300	1500	1000	1300	1300	1500

Fuel consumption - Emissions	Standard van							
	95 MPI		90 MultiJet II Comfort-Matic		105 MultiJet II		135 MultiJet II	
	E6	E6 S&S	E5+ DPF S&S	E5+ DPF	E5+ DPF S&S	E5+ ECOJet DPF S&S Ecopack	E5+ DPF	
Fuel	petrol	petrol	diesel	diesel	diesel	diesel	diesel	
Urban consumption (mpg)	27.7	30.1	50.4	39.8	44.8	48.7	38.7	
Extra-urban consumption (mpg)	47.9	47.9	54.3	55.4	55.4	60.1	54.3	
Combined consumption (mpg)	37.7	39.2	53.3	48.7	51.4	55.4	47.1	
CO ₂ emissions (g/km)	173	167	140	154	146	134	158	

Fuel consumption - Emissions	Increased payload van							
	95 MPI		90 MultiJet II Comfort-Matic		105 MultiJet II		135 MultiJet II	
	E6	E6 S&S	E5+ DPF S&S	E5+ DPF	E5+ DPF S&S	E5+ ECOJet DPF S&S Ecopack	E5+ DPF	
Fuel	petrol	petrol	diesel	diesel	diesel	diesel	diesel	
Urban consumption (mpg)	27.7	30.1	50.4	39.8	44.8	48.7	38.7	
Extra-urban consumption (mpg)	47.9	47.9	54.3	55.4	55.4	60.1	54.3	
Combined consumption (mpg)	37.7	39.2	53.3	48.7	51.4	55.4	47.1	
CO ₂ emissions (g/km)	173	167	140	154	146	134	158	

* Referred to basic versions without optional equipment

DOBLÒ CARGO

XL

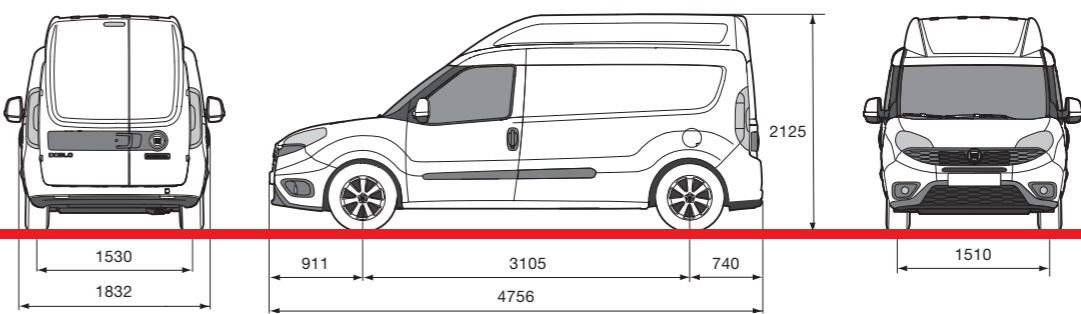

External dimensions (mm)	
Wheelbase	3105
Length	4756
Width	1832
Front track	1510
Rear track	1530
Maximum height (unladen)	2125
Front projection	911
Rear projection	740
Rear door (mm)	
Width	1231
Height	1455
Sliding side door (mm)	
Width	700
Height	1175
Load compartment (mm)	
Length	2170
Width	1714
Width between wheel arches	1230
Height	1550
Load threshold height (unladen)	545
Load compartment capacity (m ³)	
Volume	5.0

Weights	90 MultiJet II Comfort-Matic		105 MultiJet II		135 MultiJet II	
	Engine versions					
Vehicle weight * (tare) (kg)	1490		1490		1500	
Payload including driver (kg)	1005		1005		1005	
GVW (kg)	2495		2495		2505	
Max. towable weight (kg)	1300		1300		1500	

Fuel consumption - Emissions	90 MultiJet II Comfort-Matic		105 MultiJet II		135 MultiJet II	
	E5+ DPF S&S	E5+ DPF	E5+ DPF S&S	E5+ ECOJet DPF S&S Ecopack	E5+ DPF	
	Fuel	diesel	diesel	diesel	diesel	diesel
Urban consumption (mpg)	49.6	39.8	44.1	49.6	38.7	
Extra-urban consumption (mpg)	52.3	52.3	53.3	57.6	51.4	
Combined consumption (mpg)	51.4	47.1	49.6	54.3	45.6	
CO ₂ emissions (g/km)	145	158	150	137	163	

* Referred to basic versions without optional equipment

DOBLÒ CARGO
Work up

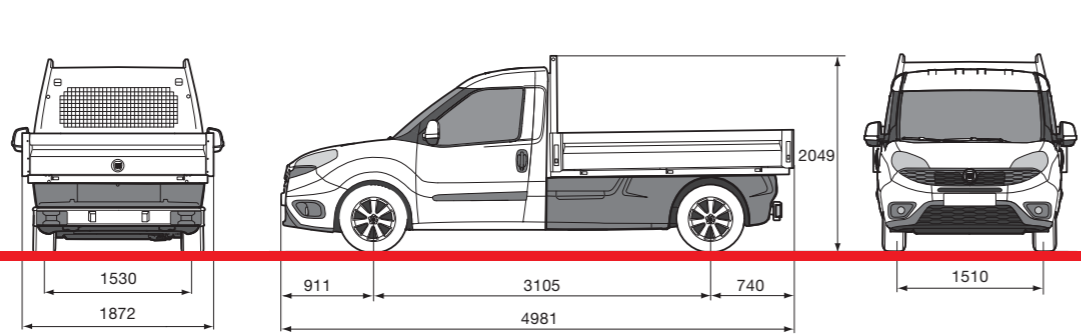

External dimensions (mm)	
Wheelbase	3105
Length	4981
Width	1872
Front track	1510
Rear track	1530
Maximum height (unladen)	2049
Front projection	911
Rear projection	803
Load compartment (mm)	
Length	2300
Width	1818
Side height	368
Load threshold height (unladen)	910
Surface area (m ²)	
Surface area	4.2

Engine versions	90 MultiJet II		105 MultiJet II		135 MultiJet II	
	Vehicle weight ▲ (tare) (kg)	1430	1510	1510	1510	1510
Payload including driver (kg)	1000	1000	1000	1000	1000	1000
GVW (kg)	2430	2510	2510	2510	2510	2510
Max. towable weight (kg)	1000	1300	1300	1300	1300	1500

Engine versions	90 MultiJet II			105 MultiJet II			135 MultiJet II
	E5+ DPF	E5+ DPF S&S	E5+ 90 HP ECOJet DPF S&S Ecopack	E5+ DPF	E5+ DPF S&S	E5+ ECOJet DPF S&S Ecopack	E5+ DPF
	diesel	diesel	diesel	diesel	diesel	diesel	diesel
Fuel							
Urban consumption (mpg)	41.5	45.6	53.3	39.8	44.1	49.6	38.2
Extra-urban consumption (mpg)	64.2	64.2	70.6	52.3	53.3	57.6	51.4
Combined consumption (mpg)	53.3	55.4	62.8	47.1	49.6	54.3	45.6
CO ₂ emissions (g/km)	140	133	118	158	150	137	163

DOBLÒ CARGO
Chassis cab with platform short wheelbase

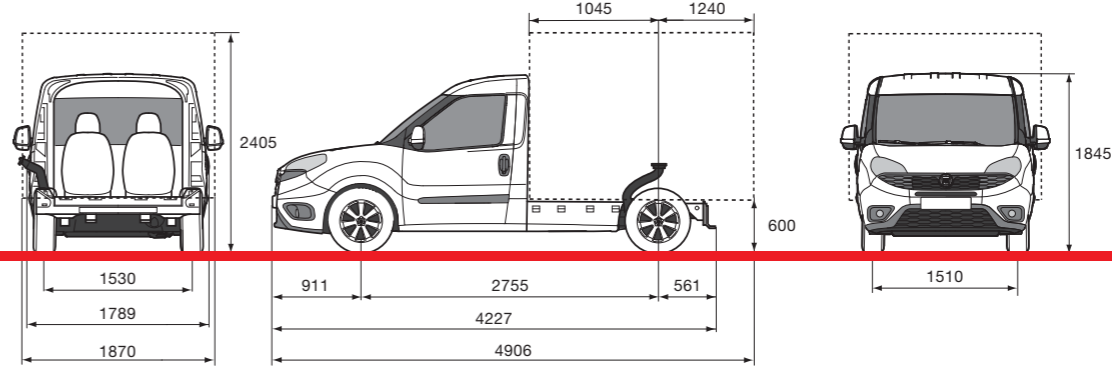

External dimensions (mm)	
Wheelbase	2755
Length	4227
Width	1789
Front track	1510
Rear track	1530
Maximum height (unladen)	1845
Front projection	911
Rear projection	561
Chassis height (STDA)	600
Rear axle span flush with the body (finished trim level projection limit) •	1240
Rear axle span behind cab	1045
Platform (mm)	
Platform length	1606
Max. theoretical practicable length •	2285
Max. theoretical practicable width •	1870
Max. theoretical practicable height •	2405

Engine versions	95 MPI	90 MultiJet II	90 MultiJet II Comfort-Matic	105 MultiJet II	135 MultiJet II
	Vehicle weight ▲ (tare) (kg)	1230	1270	1310	1310
GVW (kg)	2210	2414	2454	2454	2494
Max. permitted weight on the front axle (kg)	1120	1120	1200	1200	1200
Max. permitted weight on the rear axle (kg)	1450	1450	1450	1450	1450
Max. towable weight (kg)	1000	1000	1300	1300	1500

▲ Referred to basic versions without optional equipment

• Depending on type of trim level and weight distribution on axles
▲ Referred to basic versions without optional equipment

DOBLÒ CARGO

Chassis cab with platform long wheelbase

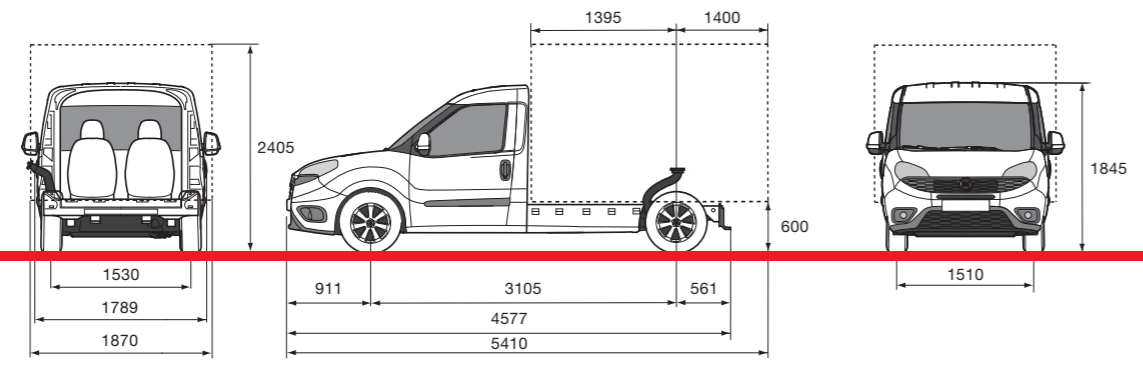

External dimensions (mm)	
Wheelbase	3105
Length	4577
Width	1789
Front track	1510
Rear track	1530
Maximum height (unladen)	1845
Front projection	911
Rear projection	561
Chassis height (STDA)	600
Rear axle span • flush with the body (finished trim level projection limit)	1400
Rear axle span behind cab	1395
Platform (mm)	
Platform length	1956
Max. theoretical practicable length •	2795
Max. theoretical practicable width •	1870
Max. theoretical practicable height •	2405

Weights					
Engine versions	95 MPI	90 MultiJet II	90 MultiJet II Comfort-Matic	105 MultiJet II	135 MultiJet II
Vehicle weight (tare) ▲ (kg)	1245	1285	1325	1325	1365
GVW (kg)	2210	2440	2480	2480	2505
Max. permitted weight on the front axle (kg)	1120	1120	1200	1200	1200
Max. permitted weight on the rear axle (kg)	1450	1450	1450	1450	1450
Max. towable weight (kg)	1000	1000	1300	1300	1500

• Depending on type of trim level and weight distribution on axles
▲ Referred to basic versions without optional equipment

DOBLÒ CARGO

Combi short wheelbase

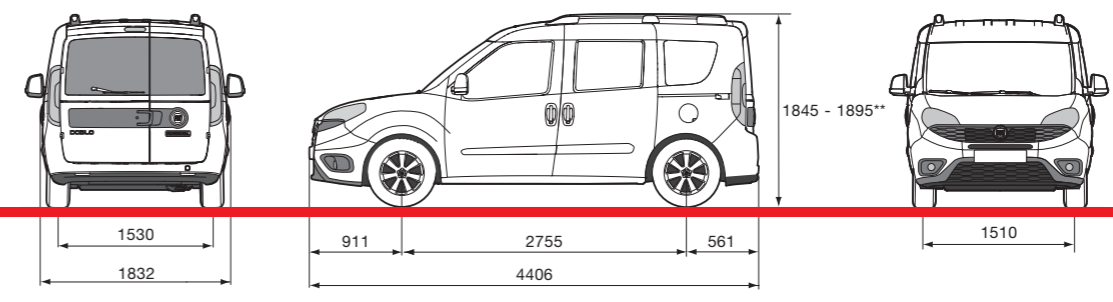

External dimensions (mm)	
Wheelbase	2755
Length	4406
Width	1832
Front track	1510
Rear track	1530
Maximum height (unladen)	1845-1895**
Front projection	911
Rear projection	740
Luggage compartment (mm)	
Length	950
Minimum width	1120
Maximum width	1195
Rear shelf level	600
Maximum height	1250
Luggage compartment capacity (m ³)	
Volume	0.79/3.2*

Weights					
Engine versions	95 MPI	90 MultiJet II	90 MultiJet II Comfort-Matic	105 MultiJet II	135 MultiJet II
Vehicle weight ▲ (tare) (kg)	1384	1434	1454	1454	1554
Payload including driver (kg)	5p + 425	5p + 425	5p + 425	5p + 425	5p + 425
GVW (kg)	2184	2234	2254	2254	2354
Max. towable weight (kg)	1000	1000	1300	1300	1500

Fuel consumption - Emissions										
Engine versions	95 MPI		90 MultiJet II			90 MultiJet II Comfort-Matic	105 MultiJet II			135 MultiJet II
	E6	E6 S&S	E5+ DPF	E5+ DPF S&S	E5+ 90 HP ECOJet DPF S&S ECOpack	E5+ DPF S&S	E5+ DPF	E5+ DPF S&S	E5+ ECOJet DPF S&S ECOpack	E5+ DPF
Fuel	petrol	petrol	diesel	diesel	diesel	diesel	diesel	diesel	diesel	diesel
Urban consumption (mpg)	28.2	30.4	42.8	47.1	53.3	50.4	41.5	46.3	52.3	38.7
Extra-urban consumption (mpg)	47.9	47.9	65.7	65.7	70.6	60.1	60.1	60.1	64.2	55.4
Combined consumption (mpg)	38.2	39.2	55.4	57.6	62.8	56.5	51.4	54.3	58.9	47.9
CO ₂ emissions (g/km)	172	166	136	129	118	133	145	138	126	156

* With back seats folded down without partition tube.
▲ Referred to basic versions without optional equipment
** Longitudinal bars with opt 357
Available in version with type approval M1
w = 75 kg

DOBLÒ CARGO
Combi maxi

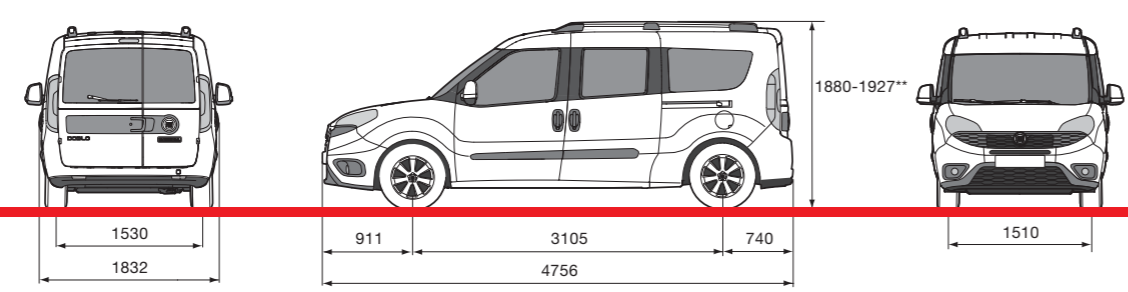

External dimensions (mm)	
Wheelbase	3105
Length	4756
Width	1832
Front track	1510
Rear track	1530
Maximum height (unladen)	1880-1927**
Front projection	911
Rear projection	740
Luggage compartment (mm)	
Length	1300
Minimum width	1191
Maximum width	1261
Rear shelf level	600
Maximum height	1250
Luggage compartment capacity (m ³)	
Volume	1.05/4.0*

Weights					
Engine versions	95 MPI	90 MultiJet II	90 MultiJet II Comfort-Matic	105 MultiJet II	135 MultiJet II
Vehicle weight ▲ (tare) (kg)	1415	1454	1549	1549	1564
Payload including driver (kg)	5p + 425	5p + 425	5p + 425	5p + 425	5p + 425
GVW (kg)	2215	2254	2349	2349	2364
Max. towable weight (kg)	1000	1000	1300	1300	1500

Fuel consumption - Emissions											
Engine versions	95 MPI		90 MultiJet II			90 MultiJet II Comfort-Matic		105 MultiJet II		135 MultiJet II	
	E6 petrol	E6 S&S petrol	E5+ DPF diesel	E5+ DPF S&S diesel	E5+ 90 HP ECOJet DPF S&S ECOpack diesel	E5+ DPF S&S diesel	E5+ DPF diesel	E5+ DPF S&S diesel	E5+ 90 HP ECOJet DPF S&S ECOpack diesel	E5+ DPF diesel	
Fuel	petrol	petrol	diesel	diesel	diesel	diesel	diesel	diesel	diesel	diesel	diesel
Urban consumption (mpg)	28.2	30.4	42.8	47.1	53.3	49.6	40.9	44.8	51.4	38.7	
Extra-urban consumption (mpg)	47.9	47.9	65.7	65.7	70.6	58.9	57.6	58.9	61.4	55.4	
Combined consumption (mpg)	38.2	39.2	55.4	57.6	62.8	55.4	50.4	52.3	57.6	47.9	
CO ₂ emissions (g/km)	172	166	136	129	118	135	148	141	129	156	

* With back seats folded down without partition tube.
 ** Longitudinal bars with opt 357
 ▲ Referred to basic versions without optional equipment
 w = 75 kg

DOBLÒ CARGO
Combi XL

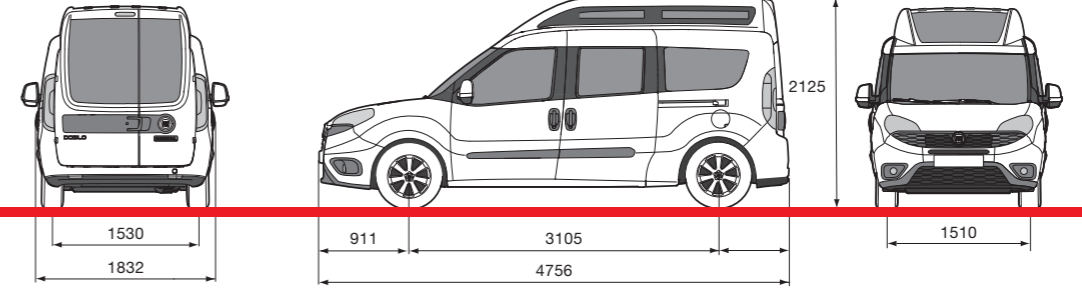

External dimensions (mm)		XL
Wheelbase	3105	3105
Length	4756	4756
Width	1832	1832
Front track	1510	1510
Rear track	1530	1530
Maximum height (unladen)	2125	2125
Front projection	911	911
Rear projection	740	740
Luggage compartment (mm)		XL
Length	1300	1300
Minimum width	1191	1191
Maximum width	1261	1261
Rear shelf level	600	600
Maximum height	1495	1495
Luggage compartment capacity (m ³)		XL
Volume	1.05/4.0*	1.05/4.8*

Weights		135 MultiJet II
Engine versions		135 MultiJet II
Vehicle weight ▲ (tare) (kg)		1624
Payload including driver (kg)		5p + 425
GVW (kg)		2424
Max. towable weight (kg)		1500

Fuel consumption - Emissions		135 MultiJet II
Engine versions		135 MultiJet II
Fuel		diesel
Urban consumption (mpg)		36.2
Extra-urban consumption (mpg)		51.4
Combined consumption (mpg)		44.8
CO ₂ emissions (g/km)		167

* With back seats folded down without partition tube.
 ▲ Referred to basic versions without optional equipment
 w = 75 kg

Standard equipment and options

		VAN	SX VAN	CHASSIS CAB WITH PLATFORM	COMBI	COMBI SX	WORK UP
EXTERIOR							
Side protection strips	927	●	●	●	●	●	●
Two asymmetric panelled rear swing doors		●	●	—	—	—	—
Two asymmetric glazed rear swing doors with heated rear window and wipers	519	○	○	—	●/○ (Maxi)	●/○ (Maxi)	—
Integral hub caps	878	●	●	○	—	—	○
15" alloy rims	108	○ ¹ /— (Maxi)	○ ¹ /— (Maxi)	—	—	—	—
16" alloy rims	431	○	○	○	○	○	○
Fog lights	097	○	●	○	○	●	○
Rear lights for platform	4EA	—	—	—	—	—	●
Front/rear splash guards	990	○	○	—	○	○	○
Rear splash guards	197	○	○	—	○	○	○
Front/rear body coloured bumpers	876	○	○	○	○	●	○
Window kit (fixed semi-glazed side section for van)	55D	○	○	—	—	—	○
Tinted rear windows	070	—	—	—	○	○	—
Nearside sliding side door	523	○/● (Maxi)	●	—	●	●	—
Offside sliding load door	055	○/● (Maxi)	○/● (Maxi)	—	○	○	—
Solid panel on quarter light	526	●	●	—	○	○	—
Rear door with two blind wings for Combi versions	516	—	—	—	○	○	—
Glazed swing tailgate, heated rear window and rear window wiper (no XL)	148	○	○	—	○/● (Maxi)	○/● (Maxi)	—
Electric door mirrors	041	○	●	○	○	●	○
Manually adjustable door mirrors	043	●	—	●	●	—	●
Folding heated electric door mirrors	341	○	○	○	○	○	○
Body coloured external mirrors	976	○	●	○	○	○	○
Metallic paintwork	210	○	○	○	○	○	○
Third brake light		●	●	—	●	●	—
Rear window on roof of load compartment	585	○/— (Maxi)	○/— (Maxi)	—	—	—	—
High roof (no 1.3 MJet)	360	○/— (Maxi) / ● (XL)	○/— (Maxi) / ● (XL)	—	○ (M1) / — (Maxi) / ● (XL)	○ (M1) / — (Maxi) / ● (XL)	—
16" alloy wheel kit (only for versions without TPMS)	50902745	△	△	—	—	—	—
INTERIOR							
Ladder bulkhead for driver	194	○	○	—	—	—	—
Fixed tube partition for combined versions (N1 type-approval)	56K	—	—	—	○	○	—
Fixed panelled bulkhead	149	●	●	—	—	—	—
Fixed panelled bulkhead with window	199	○	○	○	—	—	●
Bulkhead soundproofing	552	○	●	○	○	○	●
Passenger seat undertray	658	○	●	○	○	●	○
Leather steering wheel and gear lever knob	320	○	○	○	○	○	○
Driver's seat with armrest, lumbar and height adjustment	627	○	●	○	○	●	○
Adjustable passenger seat with storage compartment in cushion	295	○	●	○	—	—	○
Passenger seat with adjustable backrest	297	●	○	●	●	●	●
Passenger seat that folds down into a table	785	—	—	—	○	○	—
2nd row seats split, three-point seat belts and head restraint	195	—	—	—	●	●	—
Imitation leather upholstery	728	○	—	○	—	—	○
PVC load compartment mat	798	○	●	—	—	—	—
Luggage compartment mat		—	—	—	●	●	—
Loading bay cover	104	—	—	—	○	○/● (Maxi)	—
Adjustable rigid parcel shelf for luggage compartment	209	—	—	—	○/— (Maxi)	●/— (Maxi)	—
Seat covers	71805886/87	△	△	△	△	△	△
Side deflectors	71805777	△	△	△	△	△	△
Rubber mats	50902913	△	△	△	△	△	△
Pressed felt mats with Doblò logo	50902915	△	△	△	△	△	△
Carpet mats with Doblò logo	71805925	△	△	△	△	△	△
PC/PL internal platform protection	50902464/65	△	△	△	△	△	△
PC/PL internal wall protection	50902466/2739	△	△	△	△	△	△
Protective internal glass grilles for rear swing doors	50902929	△	△	△	△	△	△
FUNCTIONAL / ELECTRIC							
Remote control central door locking	008	○	●	○	●	●	○
Third remote control key	4VY	○	○	○	—	—	○
Power steering	014	●	●	●	●	●	●
Height and reach-adjustable steering wheel	011	●	●	●	●	●	●

		VAN	SX VAN	CHASSIS CAB WITH PLATFORM	COMBI	COMBI SX	WORK UP
FUNCTIONAL / ELECTRIC							
Electric front windows and electric door locking	028+228	●	●	●	●	●	●
Electric rear windows	023	—	—	—	○	○	—
Smokers' kit	989	○	○	○	○	○	○
12 V socket in dashboard		●	●	●	●	●	●
12 V socket in load compartment	4HG	○	●	—	●	●	—
Boosted battery and alternator	065	○	○	○	○	○	○
Transformer socket	081	○	○	○	—	—	○
Headlight alignment corrector	048	●	●	●	●	●	●
Load compartment roof light with removable torch	58F	○	○	—	—	—	—
Trip computer		●	●	●	●	●	●
Rev counter	044	●	●	●	●	●	●
Retaining rings in the load compartment		●	●	—	●	●	●
Roof rails (no XL)	357	○	○	—	○	○	—
Long load roof bars (inside load compartment)	983	○	○	—	—	—	—
Automatic climate control	140	○	○	○	○	○	○
Manual Air Conditioning	025	○	○	○	○	○	○
PTC heater for diesel engines	52Y	○	○	○	○	○	○
Cruise Control	416	○	○	○	○	○	○
Spare wheel, normal size	980	●	●	●	●	●	●
Parking sensors	508	○	○	—	○	○	—
Increased payload	943	○/● (Maxi & XL)	○/● (Maxi & XL)	—	—	—	●
Reinforced suspension	057	—	—	—	●	●	—
Fixed/removable tow hook	50902540/41	△	△	△	△	△	—
Monoblock tow hook	71803634	△	△	△	△	△	—
Modular alarm	50902775/81	△	△	△	△	△	—
Transverse bars on roof in al. PC/PL (70/100 kg)	50902256/58	△	△	—	—	—	—
Steel luggage box, spoiler, built-in PC/PL roller (100 kg)	50902260/59	△	△	—	—	—	—
Side ladder holder (to be mounted on roof bars)	50902597	△	△	—	—	—	—
Loading roller with extension bars	50902598	△	△	—	—	—	—
External pipe rack	50902607	△	△	—	—	—	—
Anti-tilt load blocks	50902600	△	△	—	—	—	—
Load fastening straps	50902602	△	△	—	—	—	—
1.5-m module side profiles with pipe rack	50 902603/04	△	△	—	—	—	—
SAFETY / MECHANICS							
Driver airbag		●	●	●	●	●	●
Side airbags (head + chest)	505	○	○	○	○	○	—
Passenger airbag	502	○	○	○	○	○	○
Anti-intrusion bars on cabin doors		●	●	●	●	●	●
FPS fire prevention system with inertia switch		●	●	●	●	●	●
Height-adjustable front head restraints with whiplash protection	42F	○	○	○	○	○	○
Rear head restraints	182	—	—	—	●	●	—
Safe Lock (door security system)	064	○	○	—	○	○	—
Setup for anti-theft system	388	○	○	○	○	○	—
Stop/Start - std on 1.6 MTA (n/a 1.4 petrol & 2.0 Mjet)	5DE	○	○	○	○	○	○
ECOJet pack (only on 1.6 MJet 105 HP and 1.3 MJet 90 HP)	5KQ + 5DE	○	○	○	○	○	○
ESC Electronic stability control system	392	●	●	●	●	●	●
AUDIO / TELEMATICS							
Radio / CD Player	315	●	○	●	●	○	●
Radio / CD / MP3 / AUX	41A	○	●	○	●	○	○
Radio / CD / MP3 / AUX / Bluetooth / USB	717	○	○	○	○	○	○
DAB Predisposition for Aftermarket Radios	60D	○	○	○	○	○	○
Radio controls on steering wheel	245	○	○	○	○	○	○

¹ not available for: 2.0 MultiJet, 1.4 petrol

● standard ○ optional — not available △ Mopar accessory